

**PVL-ES-SFS**  
Automatic  
**PVL-ES-MAN**  
Manual

**EN ENGLISH**

This owner's manual will provide you with information required to safely own and operate Jim Murray, Inc. ES Series pumps. The pump you have purchased is a submersible effluent pump for use in basins, effluent, wastewater and other non-explosive, non-corrosive liquids with up to 1/2" spherical solids.

The Jim Murray, Inc. ES Series unit you have purchased is of the highest quality workmanship and material. It has been engineered to give you long and reliable service.

The Jim Murray, Inc. ES Series pumps are carefully packaged, inspected and tested to ensure safe operation and delivery. When you receive your pump, examine it carefully to determine that there are no broken or damaged parts that may have occurred during shipment. If damage has occurred, make notation and notify the firm that you purchased the pump from. They will assist you in replacement or repair, if required.

**READ INSTRUCTIONS CAREFULLY BEFORE ATTEMPTING TO INSTALL, OPERATE OR SERVICE THE JIM MURRAY, INC. ES SERIES PUMP. KNOW THE PUMP APPLICATION, LIMITATIONS, AND POTENTIAL HAZARDS. PROTECT YOURSELF AND OTHERS BY OBSERVING ALL SAFETY INFORMATION. FAILURE TO COMPLY WITH INSTRUCTIONS COULD RESULT IN PERSONAL INJURY AND/OR PROPERTY DAMAGE! RETAIN INSTRUCTIONS FOR FUTURE REFERENCE.**

**SAFETY GUIDELINES**



1. Disconnect the pump from the power source before servicing or removing any component.
2. Do not use to pump flammable or explosive fluids such as gasoline, fuel oil, kerosene, etc. DO NOT use in explosive atmospheres or hazardous locations as classified by NEC, ANSI/NFPAT. Pump should be used with liquids compatible with pump component materials.
3. Do not handle the pump with wet hands or when standing on a wet or damp surface or in water.
4. Do not pull the pump out of the water by the power cord when the pump is operating or connected to power source.
5. This pump is supplied with a grounding conductor and/or grounding type attachment plug. To reduce the risk of electrical shock, be certain that it is connected to a properly grounded grounding type receptacle.
6. The National Electric Code requires a ground fault circuit interrupter (GFCI) be installed in the branch circuit supplying fountain equipment, pools, etc.
7. In any installation where property damage and/or personal injury might result from an inoperative or leaking pump due to power outages, discharge line blockage, or any other reason, a backup system(s) and/or alarm should be used.

8. Support pump and piping when assembling and when installed. Failure to do so may cause piping to break, pump to fail, motor bearing failures, etc.
9. This pump's motor housing is filled with a dielectric oil for motor heat transfer and lifetime lubrication of the bearings. This oil is non-toxic to aquatic life. However, suffocation can occur if oil is left on the water surface. If oil escapes the motor housing it can be removed from the surface quickly by placing newspapers on the water surface to soak up the oil.
10. The pump motor is equipped with an automatic resetting thermal protector and may restart unexpectedly. Protector tripping is an indication of motor overloading as a result of excessively high or low voltage, inadequate wiring, incorrect motor connections, or a defective motor or pump.

**ELECTRICAL CONNECTIONS**



1. Check the pump label for proper voltage required. Do not connect to voltage other than that shown.
2. If pump is supplied with a 3-prong electrical plug, the third prong is to ground the pump to prevent possible electrical shock hazard. DO NOT REMOVE the third prong from the plug. A separate branch circuit is recommended. Do not use an extension cord. Do not cut plug from the cord. If the plug is cut or the cord is shortened, then this action will void the warranty.
3. If the cord is equipped with stripped lead wires, such as on 230V models, be sure that the lead wires are connected to a power source correctly. The green/yellow wire is the ground. The blue (or white) and brown (or black) are live.
4. Check local electrical and building codes before installation. The installation must be in accordance with their regulations as well as the most recent National Electrical Code (NEC).
5. To conform to the National Electrical Code, all pumps must be wired with 14 AWG or larger wire. For runs to 250', 14 AWG wire is sufficient. For longer runs, consult a qualified electrician or the factory.
6. Pump should be connected or wired to its own circuit with no other outlets or equipment in the circuit line. Fuses and circuit breaker should be of ample capacity in the electrical circuit.
7. Do not modify the pump power cord except to shorten it to fit into a control panel. Any splice between the pump and the control panel must be made within a junction box and mounted outside of the basin and comply with the National Electrical Code.

**CONSULT OWNER'S MANUAL ILLUSTRATIONS FOR PROPER ASSEMBLY AND DISASSEMBLY OF YOUR JIM MURRAY, INC. ES SERIES PUMP.**

**OPERATION**

1. Install pump in a suitable basin that is at least 18" in diameter and 22" deep. Check and follow local plumbing codes.
2. Pump features a 1-1/2" female NPT discharge.
3. Clean debris and inspect basin and sump for obstructions. Pump must be placed on a hard level surface. Never place pump directly on clay, earth or gravel surfaces. Clean any sediment, mud or sand from basin.
4. A free-flow check valve that will easily pass solids should be used in the discharge line to prevent backflow of liquid into the basin.

**CAUTION:** For the best performance of check valves, when handling solids install in a horizontal position or at an angle of no more than 45°.

- Do not restrict the intake side of these pumps. Restricting the intake may cause damage to the seal and may starve the pump. If you require reduced flow rates, then place a valve on the discharge side of the pump or if flexible vinyl tubing is used, a clamp can be used on the tubing to restrict the flow.
- Do not let the unit run dry (without liquid). It is designed to be cooled by pumping fluid. You may damage the seal and the motor may fail if the pump is allowed to run dry.
- If the unit is going to be idle for a period of time, follow the cleaning instructions outlined in the next section. Do not let the unit freeze in the wintertime. This may cause cracking or distortion that may destroy the unit.

### TESTING PUMP OPERATION

#### PVL-ES-SFS AUTOMATIC

- These pumps are equipped with a float operated mechanical switch.
- When these pumps are installed in a basin with a sealed cover, switch operation cannot be observed. The sump cover usually will have a spare that is plugged with a rubber plug. This plug can be removed and switch operation can be observed.
- Plug power cord into a grounded receptacle with voltage consistent with pump voltage as indicated on pump nameplate.
- Run water into pump until pump starts.
- Be sure gate valve in discharge line is open.
- Allow pump to operate through several on off cycles.

#### PVL-ES-MAN MANUAL

- The pump cord for these pumps can be plugged directly into a properly grounded receptacle with voltage consistent with pump nameplate for continuous pump operation.

**CAUTION:** This type of operation should be used only for emergency use or when a large volume of water is to be pumped. Pump must not be allowed to run dry. If pump is run dry, it may damage pump and void the warranty.

### SERVICE INSTRUCTIONS



**MAKE CERTAIN THE UNIT IS DISCONNECTED FROM THE POWER SOURCE BEFORE ATTEMPTING TO SERVICE OR REMOVE ANY COMPONENT!**

- If pump does not operate properly, consult the troubleshooting chart. If trouble cannot be located with these steps shown, consult your pump dealer or installer (plumber).
- This unit is permanently lubricated. Oiling is not required. Do not, in any case, open the sealed portion of the unit or remove housing screws.
- Periodic cleaning of the pump parts will prolong the LIFE and EFFICIENCY of the pump. Refer to the assembly and disassembly of the pumping head.
- Remove screws that hold base to volute and clean impeller and volute passage. Do not use strong solvents on impeller.
- Be sure impeller turns freely after cleaning.
- WARNING:** DO NOT REMOVE IMPELLER. REMOVAL OF IMPELLER REQUIRES SPECIAL TOOLS AND IS TO BE DONE ONLY BY AN AUTHORIZED SERVICE CENTER. DO NOT REMOVE MOTOR HOUSING COVER. WARRANTY IS VOID IF MOTOR HOUSING COVER, IMPELLER OR SEALS HAVE BEEN REMOVED.
- Be certain power cord is in good condition and contains no nicks or cuts.

### TROUBLESHOOTING

PROBLEM	PROBABLE CAUSES	CORRECTIVE ACTION
Pump does not turn on.	Pump not plugged in.	Plug in pump.
	Circuit breaker shutoff or fuse removed.	Turn on circuit breaker or replace fuse.
	Accumulation of trash on float.	Clean float.
	Float obstruction.	Check float path and provide clearance.
	Defective switch.	Have pump serviced by authorized service center.
	Defective motor.	Have pump serviced by authorized service center.
Pump will not shut off.	Float or float rod obstruction.	Check float and float rod path and provide clearance.
	Pump is air locked.	Shut power off for approximately 1 minute, then restart. Repeat several times to clear air from pump.
	Liquid inflow matches pump capacity.	Larger pump required.
	Defective switch.	Disconnect switch, check with ohmmeter, Open = infinite resistance, closed = zero.
Pump runs but does not discharge liquid.	Check valve installed backwards.	Check flow indicating arrow on check valve body to insure it is installed properly.
	Check valve stuck or plugged.	Remove check valve and inspect for proper operation.
	Lift too high for pump.	Check rating table.
	Inlet to impeller plugged.	Pull pump and clean.
Pump does not deliver rated capacity.	Pump is air locked.	Shut power off for approximately 1 minute, then restart. Repeat several times to clear air from pump.
	Lift too high for pump.	Check rated pump performance.
	Low voltage, speed too slow.	Check for proper supply voltage to make certain it corresponds to nameplate voltage.
	Impeller or discharge pipe is clogged.	Pull pump and clean. Check pipe for scale or corrosion.
Pump cycles continually.	Impeller wear due to abrasives.	Replace worn impeller.
	No check valve in long discharge pipe allowing liquid to drain back into sump.	Install a check valve in discharge line.
	Check valve leaking.	Inspect check valve for correct operation.
	Basin too small for inflow.	Install larger basin.

**Figure 1 - Typical Installation**

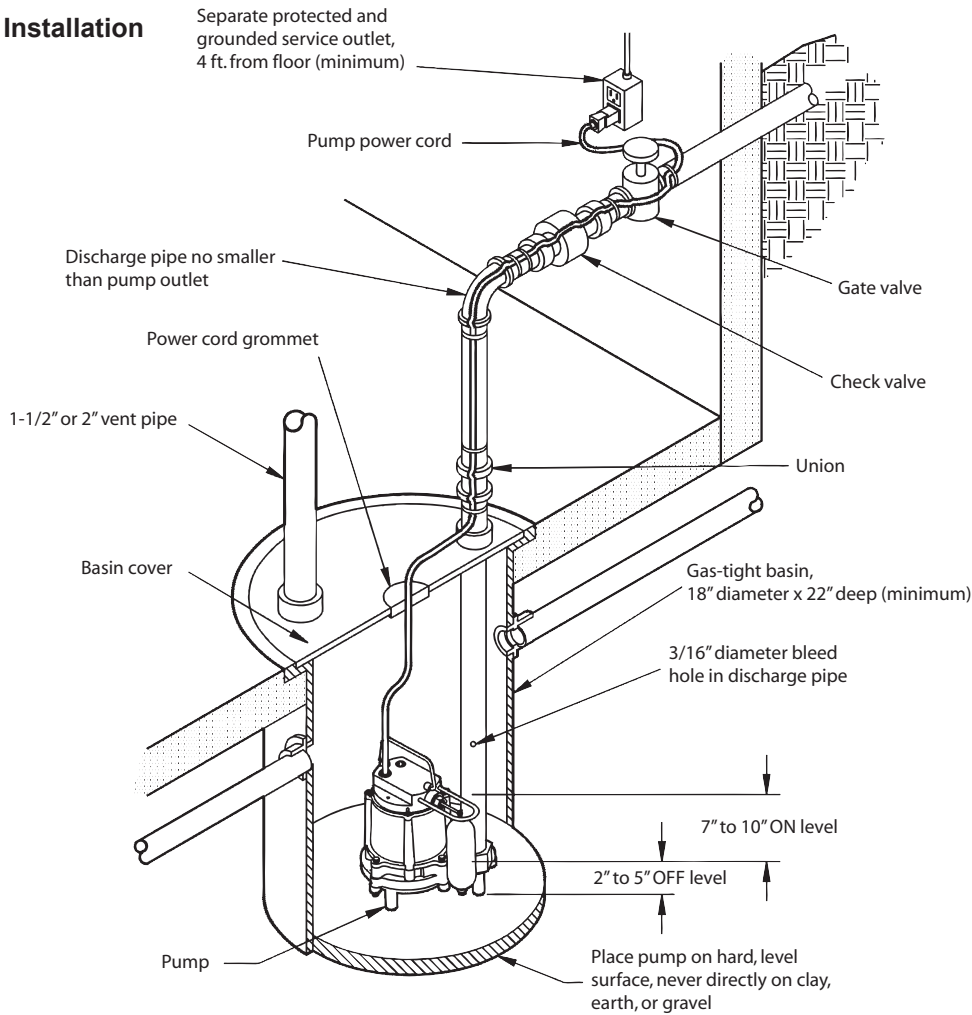

**THREE (3) YEAR LIMITED WARRANTY  
SUMP, EFFLUENT, AND RESIDENTIAL SEWAGE  
INTRODUCTION**

Jim Murray, Inc. ES Series pumps are recommended for use in sumps, basins or lift stations and suitable for pumping basement drainage water, effluent, wastewater and other non-explosive, non-corrosive, non-abrasive liquids not above 140°F with 1/2" solids handling ability. (NOT TO BE USED FOR SEWAGE WATER EXCEPT TO PUMP SEPTIC TANK EFFLUENT.)

Jim Murray, Inc. ES Series pumps are guaranteed to be in perfect condition when they leave our factory. During the time periods and subject to the conditions hereinafter set forth, Jim Murray, Inc. will repair or replace to the original user or consumer any portion of your new Jim Murray, Inc. product which proves defective due to materials or workmanship of Jim Murray, Inc. Contact your nearest Jim Murray, Inc. dealer for warranty service. At all times Jim Murray, Inc. shall have and possess the sole right and option to determine whether to repair or replace defective equipment, parts, or components. Damage due to lightning or conditions beyond the control of Jim Murray, Inc. is NOT COVERED BY THIS WARRANTY.

**WARRANTY PERIOD**

**PUMPS:** 36 months from date of purchase.

**LABOR, ETC. COSTS:** Jim Murray, Inc. shall IN NO EVENT be responsible or liable for the cost of field labor or other charges incurred by any customer in removing and/or affixing any Jim Murray, Inc. product, part or component thereof.

**THIS WARRANTY WILL NOT APPLY:**

- 1) to defects or malfunctions resulting from failure to properly install, operate, or maintain the unit in accordance with printed instructions provided.
- 2) to failures resulting from abuse, accident or negligence.
- 3) to normal maintenance services and the parts used in connection with such service
- 4) to units which are not installed in accordance with applicable local codes, ordinances and good trade practices.
- 5) unit is used for purposes other than for what it was designed and manufactured.
- 6) If pump exposed to but not limited to the following: sand, gravel, cement, grease, plaster, mud, tar, hydrocarbons, or hydrocarbon derivatives (oil, gasoline, solvents, etc.) or other abrasive or corrosive substances.

- 7) if pump has been used for continuous pumping of suitable liquids above 140°F.
- 8) if power cord has been cut or spliced
- 9) if pump has been dismantled by customer. (Dealer only can dismantle pump for field service.)

**RETURN OR REPLACED COMPONENTS:** Any item to be replaced under the Warranty must be returned to Jim Murray, Inc. or such other place as Jim Murray, Inc. may designate, freight prepaid.

**PRODUCT IMPROVEMENTS:** Jim Murray, Inc. reserves the right to change or improve its products or any portions thereof without being obligated to provide such a change or improvement for units sold and/or shipped prior to such change or improvement.

**DISCLAIMER:** Any oral statements about the product made by the seller, the manufacturer, the representatives or any other parties, do not constitute warranties, shall not be relied upon by the user, and are not part of the contract for sale. Seller's and manufacturer's only obligation, and buyer's only remedy, shall be the replacement and/or repair by the manufacturer of the product as described above. Neither seller nor the manufacturer shall be liable for any injury, loss or damage, direct, incidental or consequential (including, but not limited to, incidental or consequential damages for lost profits, lost sales, injury to person or property, or any other incidental or consequential loss), arising out of the use or the inability to use the product, and the user agrees that no other remedy shall be available to it. Before using, the user shall determine the suitability of the product for his intended use, and user assumes all risk of liability whatsoever in connection therewith. The warranty and remedy described in this limited warranty is an EXCLUSIVE warranty and remedy and is IN LIEU OF any other warranty or remedy, expressed or implied, which other warranties and remedies are hereby expressly EXCLUDED, including but not limited to any implied warranty of MERCHANTABILITY OR FITNESS FOR A PARTICULAR PURPOSE. Some states do not allow the exclusive or limitation of incidental or consequential damages, so the above limitation or exclusion may not apply to you. This warranty gives you specific legal rights, and you may also have other rights which vary from state to state.

In the absence of other suitable proof of the installation date, the effective date of this warranty will be based upon the date of manufacture plus one year. Direct all notices, etc., to: Jim Murray, Inc., N116 W18455 Morse Dr., Germantown, WI 53022.

**DETERMINATION OF UNIT DATE OF MANUFACTURE:** (9-87) month and year stamped on pump and/or serial number on pump nameplate coded to indicate year of manufacture.

Figure 2

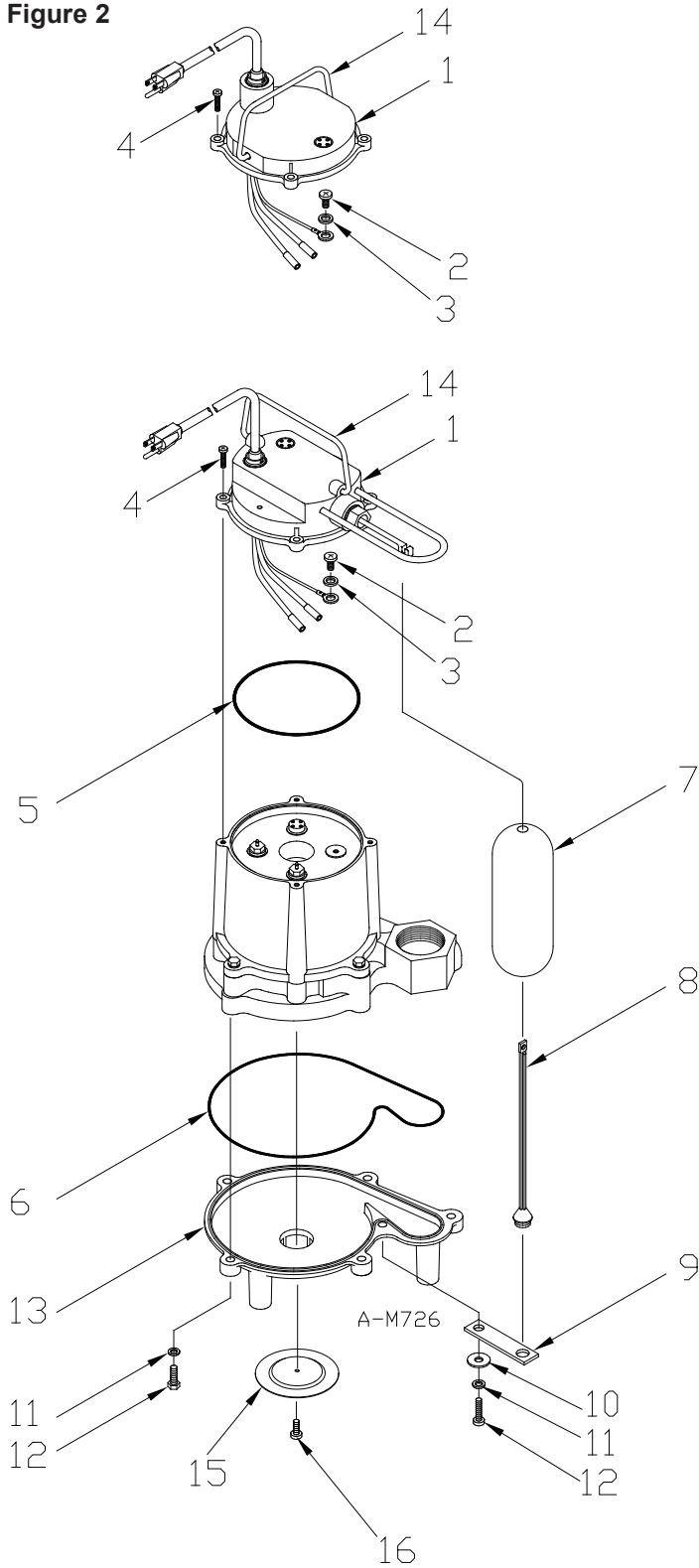

REPLACEMENT PARTS				
ITEM	PART NO.	DESCRIPTION	PVL-ES-MAN	PVL-ES-SFS
1	106408	COVER, BLACK, 10FT, CORD, MANUAL	1	
1	106398	COVER, BLACK, 10FT, CORD, W/SWITCH		1
2	902437	SCREW, #8-32 X 1/4	1	1
3	921059	WASHER, LOCK, #8, SST	1	1
4	909022	SCREW/WASHER,, #10-24 X 5/8	4	4
5	928002	SEAL RING, 4.718" X .078"	1	1
6	928039	SEAL RING, 7.928" X .078"	1	1
7	106362	FLOAT		1
8	106355	ROD, FLOAT		1
9	106354	STRAP, FLOAT		1
10	921012	WASHER, PLAIN, 1/4" SST		1
11	921103	WASHER, LOCK, 1/4" SST	6	6
12	903725	SCREW, CAP, HEX, 1/4-20 X 7/8, SST	6	6
13	106369	SCREEN/BASE, BLACK	1	1
14	108101	HANDLE	1	1
15	106121	STRAINER PLATE	1	1
16	902437	STRAINER SCREW	1	1

For Parts, Repair or  
 Technical Assistance, please contact .....262.253.1353

www.jimmurrayinc.com  
 sales@jimmurrayinc.com

# SJE-Rhombus®

## Pump Switch Installation Instructions

SJE-Rhombus® wide angle pump switches are designed to provide automatic control of pumps in non-potable water and sewage applications. The SJE PumpMaster®, SJE PumpMaster® Plus and SJE PumpMaster® SPDT pump switches passed NSF Standard 61 protocol by an approved Water Quality Association laboratory for use in potable water applications.

### SJE PUMPMASTER®



Mechanically activated pump switch for direct control of pumps in:

- Sewage
- Non-potable Water
- Potable Water

U.S. Patent Nos. 5,087,801 & 5,142,108

tether length	<b>3.5 min.</b>	<b>6</b>	<b>10</b>	<b>14</b>	<b>18</b>	<b>22</b>	<b>24</b>
pumping range	<b>7</b>	<b>10</b>	<b>16</b>	<b>22</b>	<b>28</b>	<b>33</b>	<b>36</b>

### SJE PUMPMASTER® PLUS



Mechanically activated pump switch for direct control of pumps in:

- Sewage
- Non-potable Water
- Potable Water

U.S. Patent Nos. 5,087,801 & 5,142,108

tether length	<b>3.5 min.</b>	<b>6</b>	<b>10</b>	<b>14</b>	<b>18</b>	<b>22</b>	<b>24</b>
pumping range	<b>7</b>	<b>10</b>	<b>16</b>	<b>22</b>	<b>28</b>	<b>33</b>	<b>36</b>

### SJE PUMPMASTER® SPDT



Mechanically activated pump switch for direct control of pumps in:

- Sewage
- Non-potable Water
- Potable Water

U.S. Patent Nos. 5,087,801 & 5,142,108

tether length	<b>3.5 min.</b>	<b>6</b>	<b>10</b>	<b>14</b>	<b>18</b>	<b>22</b>	<b>24</b>
pumping range	<b>7</b>	<b>10</b>	<b>16</b>	<b>22</b>	<b>28</b>	<b>33</b>	<b>36</b>

### JUNIOR SUPER SINGLE®



Mercury activated pump switch for direct control of pumps in:

- Sewage
- Non-potable Water
- Non-turbulent applications

U.S. Patent Nos. 4,429,854 & 4,572,934

tether length	<b>3.5 min.</b>	<b>6</b>	<b>8</b>	<b>10</b>	<b>12</b>	<b>15</b>	<b>17</b>
pumping range	<b>6.5</b>	<b>8.5</b>	<b>11</b>	<b>13</b>	<b>14</b>	<b>17</b>	<b>19</b>

### SUPER SINGLE®



Mercury activated pump and control switch for:

- Sewage
- Non-potable Water

U.S. Patent No. 4,302,641

tether length	<b>3.5 min.</b>	<b>5</b>	<b>7</b>	<b>9</b>	<b>13</b>	<b>15</b>
pumping range	<b>6.5</b>	<b>7.5</b>	<b>8.5</b>	<b>11</b>	<b>12.5</b>	<b>13.5</b>

### SJE AMPMASTER®



Mechanically activated pump switch for direct control of pumps in:

- Sewage
- Non-potable Water

U.S. Patent Nos. 5,087,801 & 5,142,108

tether length	<b>5 min.</b>	<b>10</b>	<b>14</b>	<b>18</b>	<b>22 max.</b>
pumping range	<b>9</b>	<b>13</b>	<b>17</b>	<b>21</b>	<b>24</b>

### PREVENTATIVE MAINTENANCE

- Periodically inspect the product. Check that the cable has not become worn or that the housing has not been damaged so as to impair the protection of the product. Replace the product immediately if any damage is found or suspected.
- Periodically check to see that the float is free to move and operate the switch.
- Use only SJE-Rhombus® replacement parts.
- The Junior Super Single® and Super Single® pump switches contain mercury and MUST be recycled or disposed of according to local, state, and federal codes.

### SJE-RHOMBUS® THREE-YEAR LIMITED WARRANTY

SJE-RHOMBUS® warrants to the original consumer that this product shall be free of manufacturing defects for three years after the date of consumer purchase. During that time period and subject to the conditions set forth below, SJE-RHOMBUS® will repair or replace, for the original consumer, any component which proves to be defective due to defective materials or workmanship of SJE-RHOMBUS®.

**THIS EXPRESS WARRANTY DOES NOT APPLY TO THE MOTOR START KIT COMPONENT. SJE-RHOMBUS® MAKES NO WARRANTIES OF ANY TYPE WITH RESPECT TO THE MOTOR START KIT.**

**ELECTRICAL WIRING AND SERVICING OF THIS PRODUCT MUST BE PERFORMED BY A LICENSED ELECTRICIAN.**

**THIS WARRANTY DOES NOT APPLY:** (A) to damage due to lightning or conditions beyond the control of SJE-RHOMBUS®; (B) to defects or malfunctions resulting from failure to properly install, operate or maintain the unit in accordance with printed instructions provided; (C) to failures resulting from abuse, misuse, accident, or negligence; (D) to units which are not installed in accordance with applicable local codes, ordinances, or accepted trade practices, and (E) to units repaired and/or modified without prior authorization from SJE-RHOMBUS®.

*Some states do not allow limitations on how long an implied warranty lasts, so the above limitation may not apply to you. Some states do not allow the exclusion or limitation of incidental or consequential damages, so the above limitation or exclusion may not apply to you. This warranty gives you specific legal rights, and you may also have other rights which vary from state to state.*

**TO OBTAIN WARRANTY SERVICE:** The consumer shall assume all responsibility and expense for removal, reinstallation, and freight. Any item to be repaired or replaced under this warranty must be returned to SJE-RHOMBUS®, or such place as designated by SJE-RHOMBUS®.

**ANY IMPLIED WARRANTIES OF MERCHANTABILITY OR FITNESS ARE LIMITED TO THE DURATION OF THIS WRITTEN WARRANTY. SJE-RHOMBUS® SHALL NOT, IN ANY MANNER, BE LIABLE FOR ANY INCIDENTAL OR CONSEQUENTIAL DAMAGES AS A RESULT OF A BREACH OF THIS WRITTEN WARRANTY OR ANY IMPLIED WARRANTY.**

**⚠ WARNING****ELECTRICAL SHOCK HAZARD**

Disconnect power before installing or servicing this product. A qualified service person must install and service this product according to applicable electrical and plumbing codes.

**⚠ WARNING****EXPLOSION OR FIRE HAZARD**

Do not use this product with flammable liquids. Do not install in hazardous locations as defined by National Electrical Code, ANSI/NFPA 70.

Failure to follow these precautions could result in serious injury or death. Replace product immediately if switch cable becomes damaged or severed. Keep these instructions with warranty after installation. This product must be installed in accordance with National Electric Code, ANSI/NFPA 70 so as to prevent moisture from entering or accumulating within boxes, conduit bodies, fittings, float housing, or cable.

*For detailed specifications on this product, or for the complete line of SJE-Rhombus® panel, alarm, and switch products, visit our web-site at [www.sjerrhombus.com](http://www.sjerrhombus.com).*

**MOUNTING THE SWITCH**

1. Determine the required cord tether length according to product specifications on the front page and as shown in Figure A.
2. Place the cord into the clamp as shown in Figure B.
3. Locate clamp at desired activation level and secure the clamp to the discharge pipe as shown in Figure B. **Note:** Do not install cord under hose clamp.
4. Tighten the hose clamp using screwdriver. Over tightening may result in damage to the plastic clamp. Make sure the float cable is not allowed to touch the excess hose clamp band during operation.
5. Follow direct wire or piggy-back instructions for further installation.

**Note:** All hose clamp components are made of 18-8 stainless steel material. See your SJE-Rhombus® supplier for replacements.

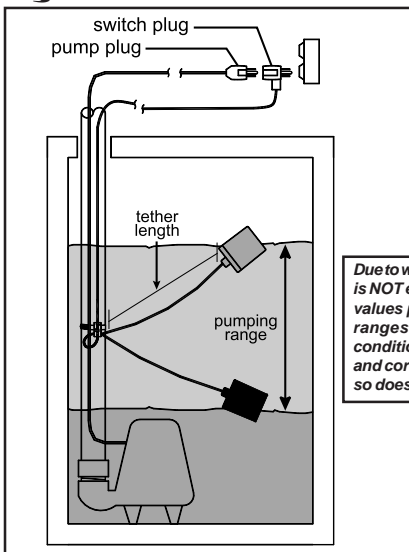
**Figure A**

*Due to weight of cable, pumping range above horizontal is NOT equal to pumping range below horizontal. Use values published on front page as a guide. Pumping ranges are based on testing in non-turbulent conditions. Range may vary due to water temperature and cord shape. Note: As the tether length increases, so does the variance of the pumping range.*

**PIGGY-BACK PLUG INSTALL**

- Electrical outlet must not be located in pump chamber.
  - Electrical outlet voltage, piggy-back plug voltage, and pump voltage must match.
1. Follow steps 1 through 4 of "Mounting The Switch."
  2. Insert switch's piggy-back plug into outlet.
  3. Plug pump into piggy-back plug as shown in Figure A.
  4. Check installation. Allow system to cycle to insure proper operation.

**DIRECT WIRE INSTALL**

1. Follow steps 1 through 4 of "Mounting The Switch."
2. Wire switch as shown below.
3. Check installation. Allow system to cycle to insure proper operation.

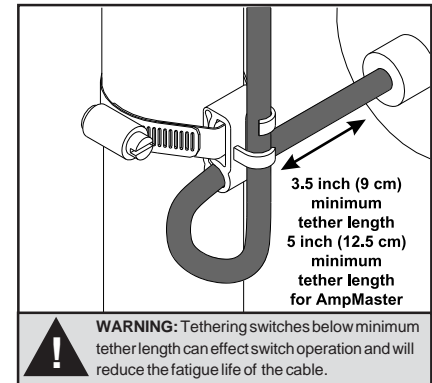
**Figure B**

**⚠ WARNING:** Tethering switches below minimum tether length can effect switch operation and will reduce the fatigue life of the cable.

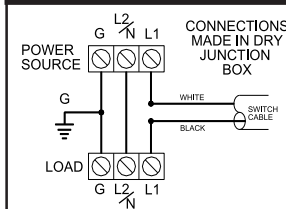
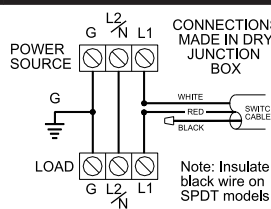
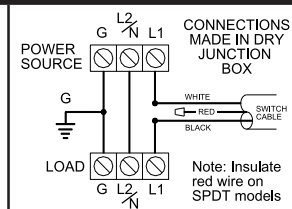
**Normally Open and Normally Closed****SJE PumpMaster® SPDT Only****Normally Closed****Normally Open****⚠ WARNING**

In 230 VAC installations, one side of the line going to the load is always **HOT**. This condition exists if the switch is on or off. Install double pole disconnect on all 230 VAC circuits.

On SPDT Models, insulate unused red or black wires with wire nut. Wire can become electrically hot.

Ensure cable connections are performed in a **dry** junction box or other watertight seal that seals both conductors and cable jacket. Failure to do so could result in electrical shock hazard and/or water traveling down cable and entering the switch. Failure to guard against this may affect switch performance.

# SJE-Rhombus®

22650 County Highway 6 ■ P.O. Box 1708 ■ Detroit Lakes, Minnesota 56502 USA  
1-888-DIAL-SJE (1-888-342-5753) ■ Phone: 218-847-1317 ■ Fax: 218-847-4617 ■ E-mail: [sje@sjerrhombus.com](mailto:sje@sjerrhombus.com)

Instl. Instr. PN 1011973J  
©SJE-Rhombus 04/08