

PumpGuard™

Pump High Water Alarm & Primary Switch
Override System

INSTALLATION INSTRUCTIONS

Dated: 4/12/07

Supersedes: 6/13/06

Document No.: PG-OM

Page 1 of 4

Notice! For use with pumps with piggyback switches only!

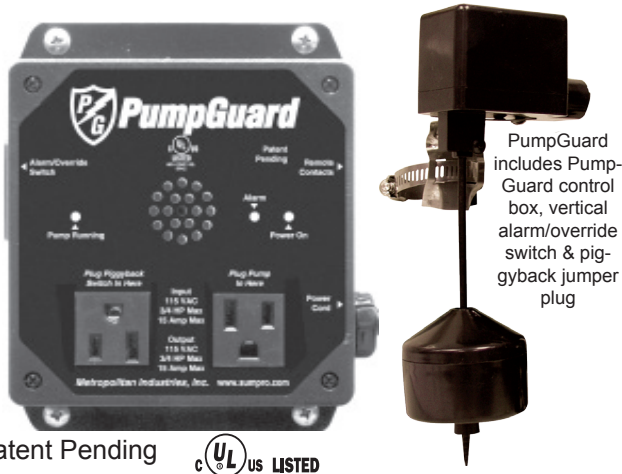
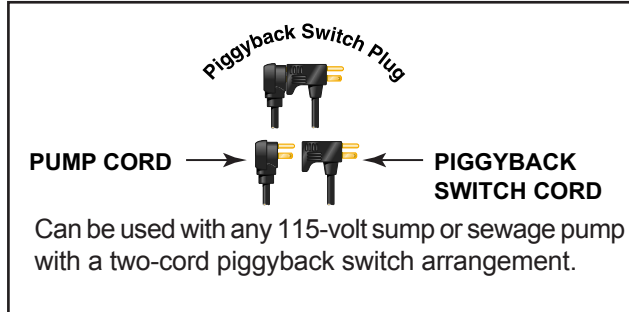

Patent Pending



! WARNING

This product has a NEMA-1 rated enclosure and can only be used in an indoor environment!

Advantages

- Two-cord piggyback pump switch arrangement.
- Added Protection, if your primary pump switch fails, the high water alarm switch will override your primary pump switch, sound the alarm and keep your pump in operation until repairs can be made.
- Remote Alarm Contacts, can be tied into your home security system or an automatic dialer to alert you to trouble when you are away from home.
- Quick and easy set up, just mount the unit on the wall, plug in your pump & switch cords, jumper plug, and alarm/override float, plug it in and you are set to go!
- PumpGuard can be plugged directly into the optional Sumpro Battery Backup System ensuring system operation during power outages.

Applications

The PumpGuard is an easy to use high water alarm/secondary pump switch override system designed specifically for use with fully automatic sump or sewage pumps with a two-cord piggyback switch system. The PumpGuard gives you the comfort of knowing that if your primary pump switch fails, the PumpGuard is there to alert you and to continue to operate your pump if your primary switch fails. Helps eliminate the possibility of unnecessary flood damage.

Specifications

Voltage:	Model #200 120 VAC, 15 amps max. running load, 1 hp or less.
Enclosure:	NEMA-1 94V0 polycarbonate plastic enclosure with all necessary electrical receptacles pre-mounted and wired for easy installation.
Alarm Switch:	Vertical float switch. Impact resistant non-corrosive PVC plastic for use in liquids up to 140°F (60°C) 10 ft. 16 gauge, 2 conductor SJOW-A (UL), SJOW (CSA) water resistant cord. NOTE: This alarm switch must be used only with the PumpGuard duplex pump alternator and alarm system.
Alarm Horn:	80 db. at 10 ft.
Indicator Lights:	Power on, Pump Running, and Alarm

PumpGuard™

Pump High Water Alarm & Primary Switch
Override System

INSTALLATION INSTRUCTIONS

Dated: 4/12/07

Supersedes: 6/13/06

Document No.: PG-OM

Page 2 of 4

Notice! This device must be used with pumps that have a two-cord piggyback switch arrangement. See Figure A.

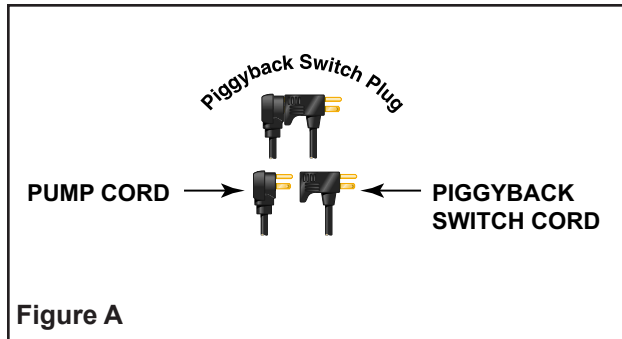

If your pump does not have the two-cord piggyback switch system shown above, you must replace the pump with one that does.

Installation

! WARNING

TURN OFF POWER SOURCE BEFORE INSTALLING OR ADJUSTING THIS DEVICE. FAILURE TO TURN OFF POWER COULD RESULT IN SERIOUS OR FATAL ELECTRIC SHOCK!

NOTE: Tank must be vented in accordance with local plumbing codes. Do Not install PumpGuard™ in locations classified as hazardous in accordance with the National Electrical Code, ANSI/NFPA 70-1993.

! CAUTION

Read these instructions carefully.

- Check local codes before installing. We recommend this product be installed in accordance with the national and local electrical codes.
- Make sure a properly grounded three prong outlet is used.
- Do not connect this product while standing on a wet or damp surface.
- Retain these instructions when installation is complete.

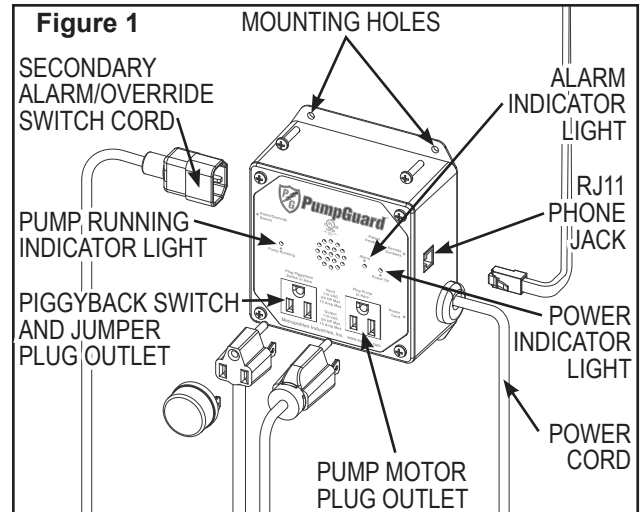

Mounting PumpGuard™ Panel

1. Determine an indoor location that is suitable for the placement of this product near the pump pit.
2. Securely mount the PumpGuard™ panel to the wall using the four mounting holes on the enclosure (see Figure 1).
3. Make sure your sump pump is properly installed.
4. Mount the alarm/override float on the pump discharge pipe and adjust it so that it will only activate at a level higher than the turn on level of the pump (see Figure 2).

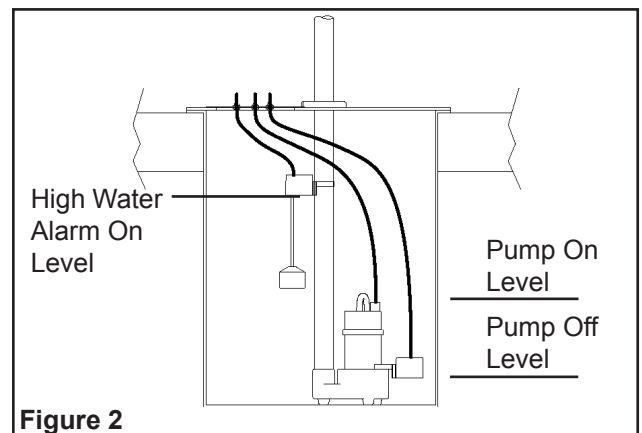

PumpGuard™

Pump High Water Alarm & Primary Switch
Override System

INSTALLATION INSTRUCTIONS

Dated: 4/12/07

Supersedes: 6/13/06

Document No.: PG-OM

Page 3 of 4

Figure 3

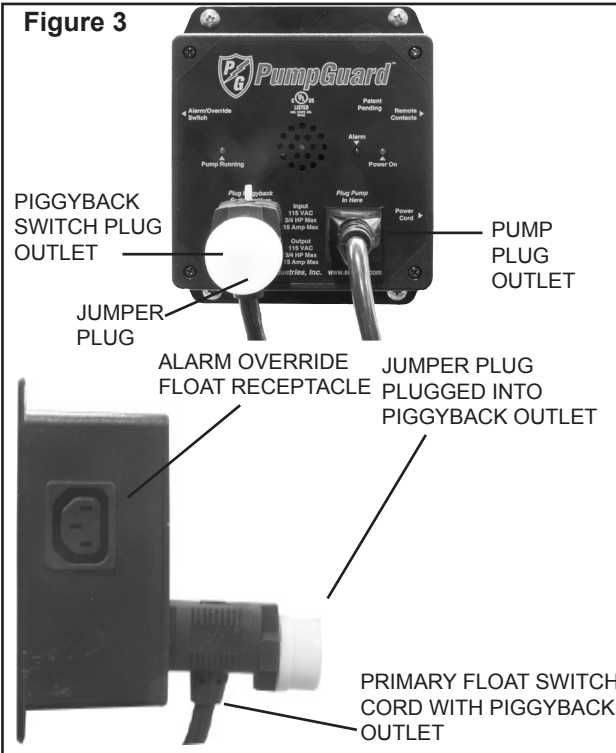

5. After all of the previous steps have been completed it is time to plug the pump cord, switch cord and alarm float into the PumpGuard™. First, separate the pump cord from the piggyback switch cord. The pump cord (plug with no piggyback receptacle) is to be plugged into the "Pump Plug Outlet" on the right hand side of the front cover (see Figure 3). The switch cord (plug with the piggyback receptacle) is plugged into the "Piggyback Switch Plug Outlet" on the left hand side of the front cover (see Figure 3). Once the cords are plugged into the proper receptacles, the jumper plug must be plugged into the back of the piggyback switch plug (Located on the left side) to complete the circuit (see Figure 3). The alarm float must be plugged into the receptacle on the left-hand side of the enclosure.

6. Now that all of the wiring has been properly connected, plug the PumpGuard™ into the designated receptacle.

7. Fill the pump tank with water and allow the system to cycle several times to ensure proper operation. By lifting the alarm float you should activate the alarm and run the pump. Note, the PumpGuard™ alarm/override switch, when activated, will sound the audible alarm and activate the pump whether the primary switch has failed or not.

8. The PumpGuard™ also has a set of remote contacts that can be tied into a home alarm system or external dialer for added protection. The receptacle is a standard RJ 11 phone jack residential 6x4 quad. The active wires are pins 3 and 4, which are the red and green wires in the cable. The red and green wires can be tied directly into a home alarm system, an automatic dialer or any other type of remote sensing device. (See Figure 4)

Figure 4

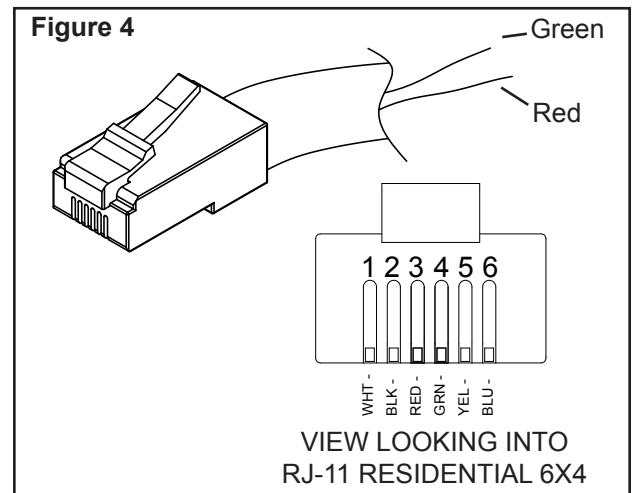

Typical Installation

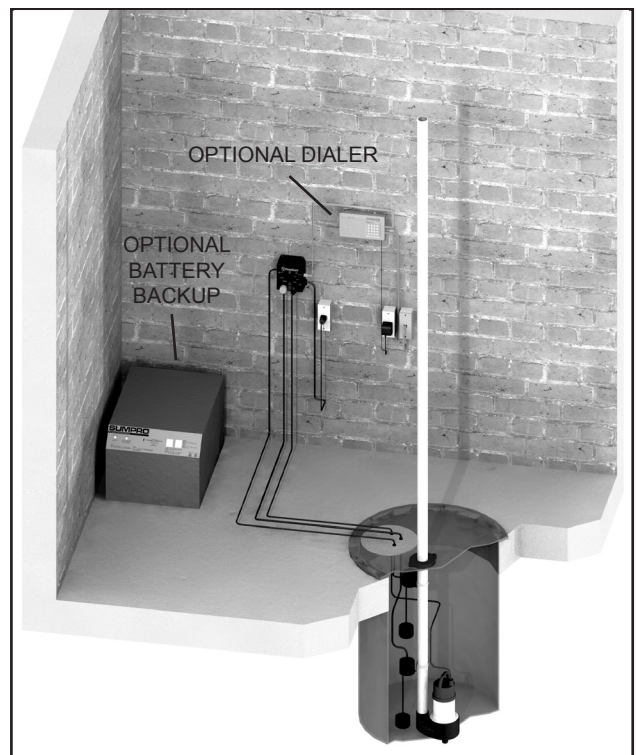

PumpGuard™

Pump High Water Alarm & Primary Switch
Override System

INSTALLATION INSTRUCTIONS

Dated: 4/12/07

Supersedes: 6/13/06

Document No.: PG-OM

Page 4 of 4

WARRANTY

1. Coverage and Term. Metropolitan Industries, Inc. (“**Metropolitan**”) warrants to the original purchaser (the “Buyer”) of each Metropolitan product (the “product”), that any part thereof which proves to be defective in material or workmanship within one (1) year from date of installation or 18 months from the date of manufacture, whichever comes first, will be replaced at no charge with a new or remanufactured part, F.O.B. factory. Buyer shall be responsible for all freight charges and all costs of field labor or other charges incurred in the removal and/or reinstallation of any product, part or component thereof.
2. Exclusions. **THE WARRANTY IS SUBJECT TO THE FOLLOWING CONDITIONS AND EXCLUSIONS:**
 - (a) The Warranty excludes products or workmanship which becomes defective as a result of: (i) earthquake, fire, storms, the elements or any other acts of God; (ii) normal wear and tear from use; (iii) accident, misuse, abuse or neglect ; (iv) modifications made by Buyer or any third party, other than **Metropolitan**; and (v) Buyer’s failure to properly install, maintain, service and/or operate the product under normal conditions and according to manufacturer’s instructions.
 - (b) **Metropolitan** shall not be responsible for, and the Warranty shall not cover, extended damage which occurs because of Buyer’s failure to notify **Metropolitan** promptly in writing of apparent defects.
 - (c) Any part or component designated as manufactured by anyone other than **Metropolitan** shall be covered only by the express warranty of the manufacturer thereof.
 - (d) The Warranty shall lapse upon Buyer’s failure to fully comply with the terms and conditions of its contract with **Metropolitan**, including Buyer’s failure to pay the purchase price for the product or any portion thereof. Buyer’s subsequent compliance with the terms and conditions of any such contract, will not cause the term of the Warranty to extend beyond the time period set forth above.
 - (e) No actions taken by **Metropolitan** to correct a defect in a product shall extend the Warranty beyond the period set forth above. **Metropolitan** shall not be obligated to remedy any defect, where otherwise required pursuant to the Warranty unless and until Buyer notifies **Metropolitan** in writing of the defect and then only if such notification is made prior to the expiration of the period set forth above.
3. Process of Claims and Repairs. **Metropolitan** agrees that if the product or any part or component thereof shall fail to conform to the terms of this Warranty, **Metropolitan** shall replace such nonconforming product, part or component at the original point of delivery and furnish instruction for its disposition. Any transportation charges involved in such disposition and all costs of field labor or other charges incurred in the removal and/or reinstallation of any product, part or component thereof shall be the responsibility of Buyer.
4. Limitation on Liability. Notwithstanding any provision to the contrary, **Metropolitan’s** entire liability under this Warranty shall not in the aggregate exceed, and Buyer’s exclusive and sole remedies are, to the extent permitted by law, shall be to secure replacement of the defective product. **UNDER NO CIRCUMSTANCES SHALL METROPOLITAN BE LIABLE UNDER THE WARRANTY FOR ANY INDIRECT, PUNITIVE, SPECIAL, EXEMPLARY, CONSEQUENTIAL OR INCIDENTAL DAMAGES (INCLUDING LOST PROFITS, REVENUE, USE OR ECONOMIC ADVANTAGE).**
5. Express Waiver of Any Other Warranties. **THE EXPRESS WARRANTY SET FORTH IN THIS WRITTEN WARRANTY IS THE ONLY WARRANTY MADE BY METROPOLITAN, OR ANY OTHER PARTY, IN CONNECTION WITH ANY PRODUCT PURCHASED FROM METROPOLITAN. NEITHER METROPOLITAN, NOR ANY OTHER PARTY, MAKES ANY OTHER EXPRESS OR IMPLIED WARRANTY WHICH IS NOT SET FORTH HEREIN, AND METROPOLITAN HEREBY DISCLAIMS AND BUYER HEREBY WAIVES ALL IMPLIED WARRANTIES, INCLUDING THE IMPLIED WARRANTY OF MERCHANTABILITY AND THE IMPLIED WARRANTY OF FITNESS FOR A PARTICULAR PURPOSE.**
6. Not Transferable. The Warranty may not be transferred and shall be void on the sale or other transfer of the product.
7. Products and Warranty Subject to Change. **Metropolitan** reserves the right to make revisions to its products and their specifications, and to revise this Warranty and related information without notice.