



PZM-EP PUMP SERIES

Thank you for purchasing an EnergyPro pump. Take the time to read the instructions carefully before using this appliance. We strongly recommend that you keep this instruction manual in a safe place for future reference

SPECIFICATIONS

Model	Output		Discharge		Rated		Maximum		Dimension L x W x H	Weight Lbs.
	(Hp)	(Amp)	(mm)	(Inch)	Head(ft)	Flow(GPM)	Head(ft)	Flow(GPM)		
PZM-EP-33M	1/3	250	40	1-1/2"	10	50	25	68	7.9" x 5.5" x 12.6"	13.5
PZM-EP-50M	1/2	400	50	2"	10	70	30	87	9.1" x 6.3" x 13.8"	14.5
PZM-EP-75M	3/4	550	50	2"	10	84	35	97	9.1" x 6.3" x 15"	22.5

- Check the nameplate for your pump's specification, refer to the table list.
- Be careful not to exceed the given specifications in the use of your pump.

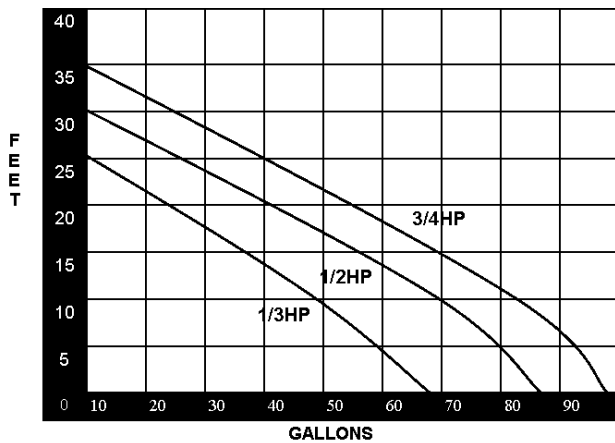

MARKS AND MEANING:



DANGER

Keep the pump equipment out of the reach of children!
Warns that the failure to follow the directions given could cause serious risk to individuals or objects.



WARNING

This sign warns the operator that the failure to follow an instruction may damage the pump and/or the system.

LIMITATIONS:

This pump series is suitable to pump water and also can be used both for permanent and temporary installation. The pump can be placed in a sump pit that means it could pump rain water containing suspended solid particles 6-10mm in diameter.



The pump can be used for sea water but not inflammable, corrosive, explosive or dangerous liquids. Make sure that the pump never runs without liquids.

INSTALLATION:

Do not work on pump until power is unplugged.
Do not cut off ground pin or use an adapter fitting.
Do not use an extension cord.

The pump power cord should be connected to a separately fused, grounded line with a minimum capacity of 15 amps. It can be connected to non-fuse breaker as the recommended amperes.

Never touch the pump when it is connected to electrical power.

1. Before installing or servicing this pump, be certain pump power source is disconnected.
2. Installation and electrical wiring must adhere to state and local codes and must be completed before priming pump. Check appropriate community agencies, or contact local electrical and pump professionals.
3. Call an electrician when in doubt. Pump should be connected to a separate 15 amps circuit breaker or 15 amp fuse block. Note that, plugging into existing outlets may cause low voltage at motor, causing blown fuses, tripping of motor overload, or burned out motor.
4. A permanent ground connection from pump to the grounding bar at the service panel is mandatory, EnergyPro sump pumps come with a grounding conductor and a grounding-type attachment plug. Do not connect pump to a power supply until permanently grounded. For maximum safety, connect pump to a circuit equipped with a fault interrupter device when you position the pump's grounding wire.
5. Voltage of power supply must match the voltage of the pump.
6. Before installing pump, clear sump basin of any water, debris or sediment.
Warning: Sump basin must be vented in accordance with local plumbing codes. EnergyPro Sump pumps are not designed for and CANNOT be installed in locations classified as hazardous
7. The following may cause severe damage to pump and will void the warranty:
 - (a) Using an extension cord.
 - (b) Cutting off the ground pin or using an adapter fitting.
 - (c) Working on pump or switch while plugged in.
 - (d) Removing motor housing, unscrewing impeller, or otherwise removing impeller seal
 - (e) Running the pump continuously.
 - (f) Pumping chemicals or corrosive liquids.
 - (g) Pumping gasoline or other flammable liquids.
 - (h) Piping, plastic PVC pipe could be installed in the outlet piping, but drain hose, galvanized steel or copper pipe may be used if desired. All piping must be clean and free of all foreign matter to prevent clogging. Use thread compound on all threaded joints unless specified otherwise. Be sure to seal the thread connection with tape when your using the pipe fitting to connect the flange.
 - (i) Pump will be inadequate if suspension liquids contain solid particles larger than the strainer's holes.



ELECTRICAL WIRE CONNECTION:



Verify that the voltage and frequency of the pump shown on the nameplate correspond to those available on the mains.

The installer must make sure that the electric system is grounded in accordance with the law in force.

- It is necessary to use cable with a length of 10m for outdoors. The plug and connections should be protected from water splashes. Before using the pump, always inspect it visually (especially power cable and plug).
- Do not use the pump if it is damaged.
- If the pump is damaged, have it inspected by an authorized service center only.
- Make sure that electric connections are protected from inundation. Protect the plug and the power cable from heat, oil or sharp edges.



The power cable must be replaced by qualified personnel only.

Grounding: The plug of the power cable has a double grounding contact, so that grounding can be performed by simply inserting the plug

OVERLOAD PROTECTION:

This pump series has a built in thermal protection switch. The pump stops if an overload condition occurs. The motor restarts automatically after it has cooled down

TROUBLESHOOTING CHECKLIST (CAUTION: SHUT OFF POWER TO PUMP)

PROBLEMS	POSSIBLE CAUSES
Pump does not run and hums	<ul style="list-style-type: none"> • Line circuit breaker is off, or fuse is burned or loose. • Water level in sump has not reached turn-on level as indicated in installation drawing. • Pump cord is not making contact in receptacle. • Float is stuck. It should operate freely in basin. • If all of the above are OK, then the motor could be malfunctioning.
Pump runs but does not deliver water.	<ul style="list-style-type: none"> • Check valve is installed backwards. Arrow on valve should point in direction of flow. • Discharge shut-off valve (if used) may be closed. • Impeller or volute openings are fully or partially clogged. Remove pump and clean. • Pump is air-locked. Start and stop several times by plugging and unplugging cord. Check for clogged vent hole in pump case. • Inlet holes in pump base are clogged. Remove pump and clean the openings. • Vertical pumping distance is too high. Reduce distance or change the discharge fittings of the pump.
Pump runs and pumps out sump, but does not stop	<ul style="list-style-type: none"> • Float is stuck in up position. Be sure float operates freely in basin. • Defective float switch. Replace with float switch. • Defective vertical switch. Replace with vertical switch.
Pump runs but delivers only a small amount of water.	<ul style="list-style-type: none"> • Pump is air-locked. Start and stop several times by plugging and unplugging cord. Check for clogged vent hole in pump case. • Vertical pumping distance is too high. Reduce distance or change the discharge fitting of the pump. Inlet holes in pump base are clogged. Remove pump and clean the strainer and openings. • Impeller or volute openings are fully or partially clogged. Remove pump and clean. • Pump impeller is partially clogged with tar or paint, causing motor to run slow and overload. Remove pump and clean.
Fuse blows or circuit breaker trips when pump starts.	<ul style="list-style-type: none"> • Pump impeller is partially clogged with tar or paint, causing motor to run slow and overload. Remove pump and clean. • Motor stator may be defective. • Fuse size or circuit breaker may be too small. (Must be 15 amps). • Impeller or volute opening are fully or partially clogged. Remove pump and clean
Motor runs for a short time, then stops.	<ul style="list-style-type: none"> • Inlet holes in pump base are clogged. Remove pump and clean the openings. • Pump impeller is partially clogged with tar or paint, causing motor to run slow and overload. Remove pump and clean. • Motor stator may be defective. • Impeller or volute openings are fully or partially clogged. Remove pump and clean also clean the strainer if you had installed.



WARNING

ELECTRICAL PRECAUTIONS—

Before servicing a pump, always shut off the main power breaker and then unplug the pump. Make sure you are not standing in water and are wearing insulated protective sole shoes, under flooded conditions, Contact your local electric company or a qualified licensed electrician for disconnecting electrical service prior to pump removal.

CONSTRUCTION AND PARTS LIST

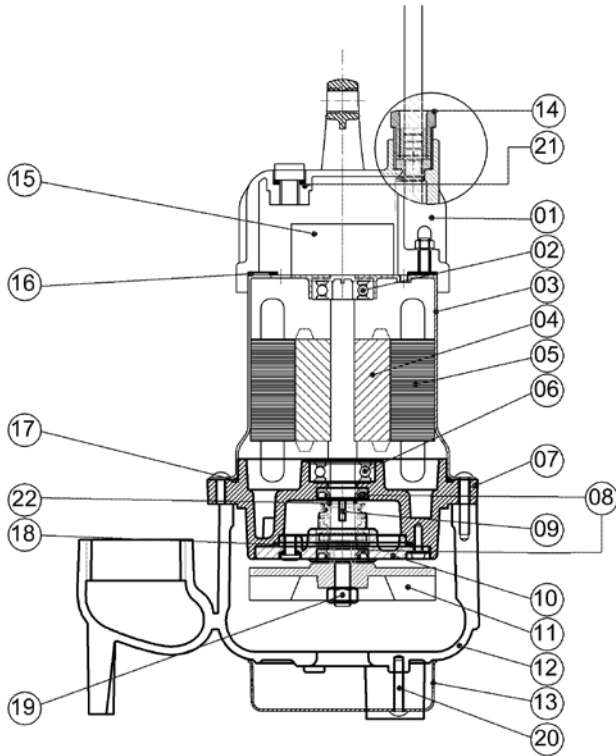

22	C Retaining Ring	SUS
21	Plug Screw	COATED STEEL
20	Setting Screw	SUS
19	Nut	SUS
18	O-Ring	NBR
17	O-Ring	NBR
16	Cap Packing	NBR
15	Capacitor	PP
14	Power cord set	H05RNF/H07RNF
13	Strainer	SUS304
12	Pump Casing	FC200
11	Impeller	FC200
10	Seal Cover	FC200
09	Me.Seal	CA/CE
08	Oil Seal	NBR
07	Seal Plate	FC200
06	Lower Bearing	CNM5K
05	Stator	SUS304
04	Shaft	SUS410
03	Motor Housing	SUS304
02	Upper Bearing	CNM5K
01	Top Cover	NL66+30%GF
NO.	Name	Description

LIMITED WARRANTY

This EnergyPro pump is warranted to be free from defects in material and workmanship and to perform within applicable specifications for a period of Two (2) years. Obligation under this warranty is limited to repairing or replacing any part thereof, which shall within two years be returned to us with transportation charges prepaid, and prove to be defective.

The above limited warranty takes the place of all other warranties, express or implied and correction of such defects by replacement or repair shall constitute a fulfillment of all obligations under the terms of the warranty, which specifically EXCLUDES any incidental damages caused by or associated with this product or its use. The warranty does not cover any unit which has been damaged either in transit or by misuse, accident or negligence. No warranty or representation not contained herein shall be binding.



JIM MURRAY, INC.
Your Partners in Pumping Since 1958

N116 W18455 Morse Drive
Germantown, WI 53022
262-253-1353 / 800-234-5490
Fax 262-253-1248